

Torque Sensor

Series 3000 and Series 4000



Properties

- Sensor shaft with integrated torque and angle measurement
- Non-contact measurement system, high robustness
- “Plug & Play” solution, no additional electronics required

Performance

- Measurement range from 50 Nm to 2000 Nm
- Accuracy class 0,1 % / 0,2 %
- Temperature range -40 °C ... +105 °C
- IP50
- Turning speed up to 10000 rpm
- Output Signals 0-10 V / 4-20 mA / PWM / Frequency

1. Short description

With this torque sensor the effective torque on the gauge bar can be measured bi-directionally independent from rotational speed. The sensor is delivered as a complete unit with corresponding connecting cable and key stones. The transmitting shaft, the contact-free signal pick-up and the analog signal processing are integrated into the sensor structure. No external amplifier is needed. Based on magnetic field and therefore completely non-contact measurement principle the sensor works totally maintenance-free over a wide temperature range.

2. Model Series 3000 / Series 4000

Series 3000 / Series 4000		Nominal-Torque	Max. overload	Rotational Speed
Shaft	Unit	Bi-directional (+/-)	Bi-directional (+/-)	[rpm]
15 mm	[Nm]	50	150	10.000
	[ft-lb]	37	111	
15 mm	[Nm]	100	150	10.000
	[ft-lb]	74	111	
25 mm	[Nm]	250	750	8.000
	[ft-lb]	184	553	
25 mm	[Nm]	500	750	8.000
	[ft-lb]	369	553	
40 mm	[Nm]	1000	3000	5.000
	[ft-lb]	738	2213	
40 mm	[Nm]	2000	3000	5.000
	[ft-lb]	1475	2213	

Torque Sensor

Series 3000 and Series 4000

3. Technical Characteristics of the Sensor

No.	Accuracy class ¹⁾	Unit	Series 3000	Series 4000				
			0,2	0,1				
		Unit	Value					
1	Linearity deviation incl. hysteresis	%ME*	< ±0.2	<±0.1				
2	Rotational Signal Uniformity (RSU)	%ME*	< ±0.2	<±0.1				
3	Repeatability	%ME*	< ±0.05	<±0.05				
Output signal in general		Unit	Value					
4	Frequency range, -3dB point, Bessel characteristics	Hz	0 ... 2500					
5	Analog signal	V	0 ... 10					
6	Signal at torque = Zero ²⁾	V	≈ 5					
7	Signal at positive nominal torque	V	≈ 9					
8	Signal at negative nominal torque	V	≈ 1					
9	Calibration parameter	mV/Nm	≈ 4000 mV / Measurement range					
10	Output resistance	Ω	62					
Effect of temperature		Unit	Value					
11	Zero point drift over temperature	%/10K	< 0.2					
12	Signal drift over temperature within operational temperature range ³⁾	%/10K	< 0.5					
Power supply		Unit	Value					
13	Supply voltage	VDC	11 ... 28					
14	Current consumption (max.)	mA	150					
15	Start-up peak	mA	< 200					
16	Absolute max. supply voltage	VDC	30					
General information		Unit	Value					
17	Degree of protection acc. to EN 60529	IP	50 (64 if required)					
18	Reference temperature	°C	+15 ... +35					
19	Operational temperature range	°C	-30 ... +85					
20	Storage temperature range	°C	-30 ... +100					
Nominal torque M (bi-directional)		Nm	50	100	250	500	1000	2000
21	Weight	kg	1.4	2.4	6			
22	Moment of inertia round shaft	kg*mm ²	5.9	59.5	626			

%ME: related to a full scale measurement range

- 1) The accuracy class implies that taken separately both the linearity deviation as well as the rotational signal uniformity are either lower than or equal to the value of the accuracy class. The accuracy class is not to be identified with the classification following DIN 51309 or EA-10/14.
- 2) Zero point can be set to 5 V by pressing the Tera-button.
- 3) The factor of transmission declines linearly up to a maximum of 0,5 % / 10K with rising temperature due to the reduction of the elasticity.

Torque Sensor

Series 3000 and Series 4000

	EMI / EMC	Unit	Wert		
	Tested Standards				
23	EN 61000-6-3: 2007	-	PASSED		
24	EN 55011: 2009 + A1: 2010 class B	-	PASSED		
25	EN 61000-6-2: 2005	-	PASSED		
26	EN 61000-4-2 (ESD) : 2009	-	PASSED		
27	EN 61000-4-3 (HF) : 2006 + A1: 2008 + A2: 2010	-	PASSED		
28	EN 61000-4-4 (BURST): 2004 + A1: 2010	-	PASSED		
29	EN 61000-4-5 (Surge): 2006	-	PASSED		
30	EN 61000-4-6: 2009	-	PASSED		
31	EN 61000-4-8: 2010	-	PASSED		
32	EN 61000-4-11: 2004	-	PASSED		
	Load limits⁴⁾	Unit	Value		
33	Maximum measurable torque	%	110		
34	Maximum torque, related to nominal torque	%	300		
35	Ultimate torque	%	500		
36	Maximum load of key stone (Application factor 1,5)	%	180	200	200

- 4) Based on the non-contact measurement principle the torque sensor is quite insensitive to bending and shearing forces. Self-aligning couplings are recommended in case of dynamic loads.

Torque Sensor

Series 3000 and Series 4000

4. Available Options

4.1 Optional Signal Outputs

In addition to the analog output signal the Series 3000 und Series 4000 can also be delivered with another optional output signal as listed below.

Frequency output		
Description	Unit	Value
Basic frequency	kHz	60
Measurement range	kHz	20 ... 100
Calibration parameter	kHz/Nm	40 / Measurement range

Current output		
Description	Unit	Value
Signal at torque = zero	mA	12
Measurement range	mA	4 ... 20
Calibration parameter	mA/Nm	8 / Measurement range

PWM-signal output		
Description	Unit	Value
Carrier frequency	Hz	980
Signal at torque = zero	%	50
Measurement range	%	10...90
Error indication	%	95
Calibration parameter	%/Nm	40 / Measurement range

Only the analog voltage output is calibrated by default. All other output signals are adjusted according to the analog voltage output.

4.2 Optical angle sensor

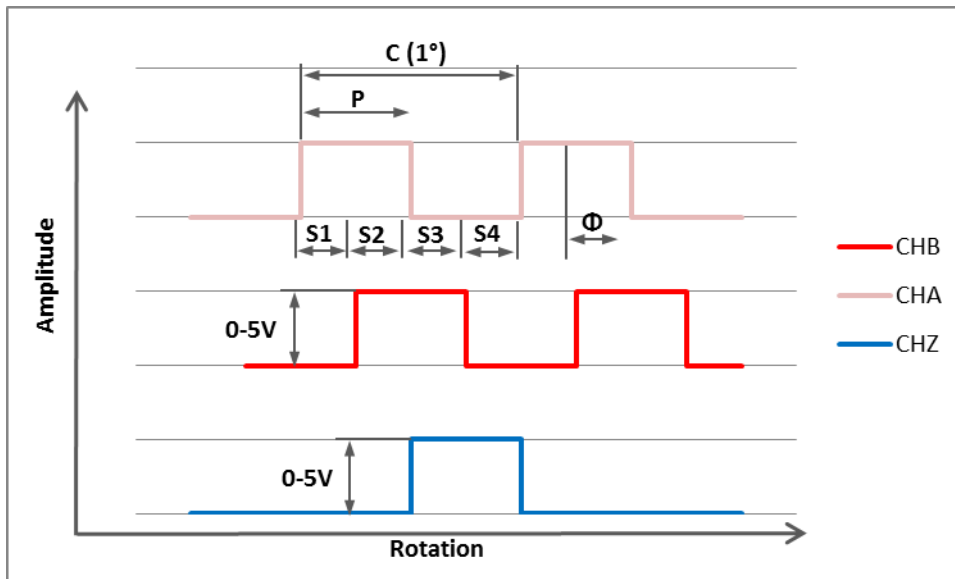

Parameter	Symbol	Unit	Regular	Min.	Max.
Cycles (optical)	n		360		
Cycle error	ΔC	Degree ⁷⁾	0.8×10^{-2}		4.2×10^{-2}
Pulse width error	ΔP	Degree ⁷⁾	1.9×10^{-2}		8.3×10^{-2}
State width error	Δs_x	Degree ⁷⁾	1.4×10^{-2}		8.3×10^{-2}
Phase error	$\Delta\phi$	Degree ⁷⁾	0.6×10^{-2}		4.2×10^{-2}
Index pulse width	P_0	Degree ⁷⁾	0.25	0.17	0.33
Ch I rises after Ch B or Ch A falls	t_1	ns	100	10	1000
Ch I rises after Ch A or Ch B rises	t_2	ns	300	10	1000
Rise-time	t_r	ns	180		
Fall-time	t_f	ns	50		

7) Degree is with respect to the rotation.

Torque Sensor

Series 3000 and Series 4000

5. Dimensions

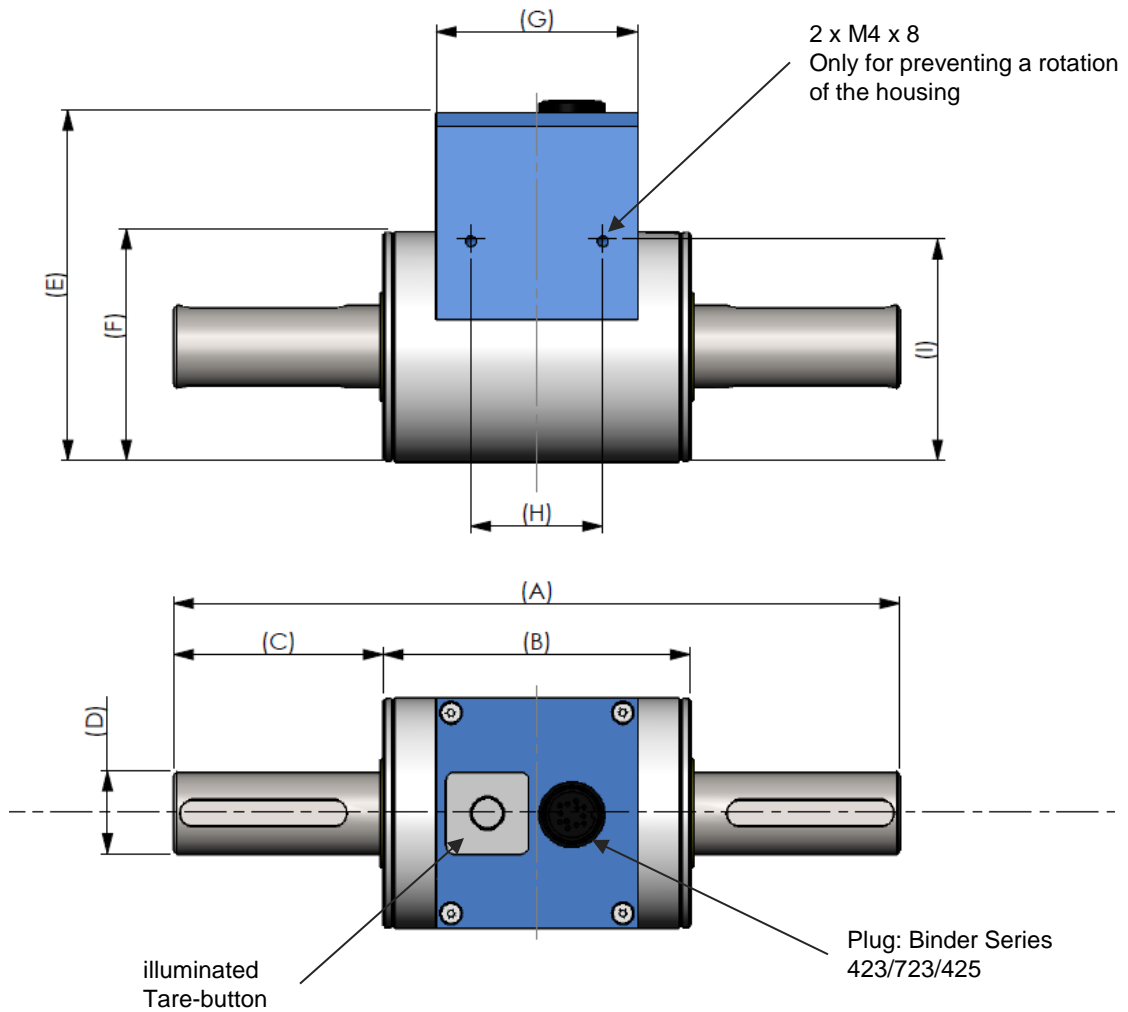

Dimensions (in mm):									
	A	B	C	D	E	F	G	H	I
50 Nm	160	93	33,5	15g6	96	60	61	40	57
100 Nm	160	93	33,5	15g6	96	60	61	40	57
250 Nm	220	93	63,5	25g6	106	70	61	40	67
500 Nm	220	93	63,5	25g6	106	70	61	40	67
1000 Nm	350	130	110	40g6	126	90	80	60	87
2000 Nm	350	130	110	40g6	126	90	80	60	87

Torque Sensor

Series 3000 and Series 4000

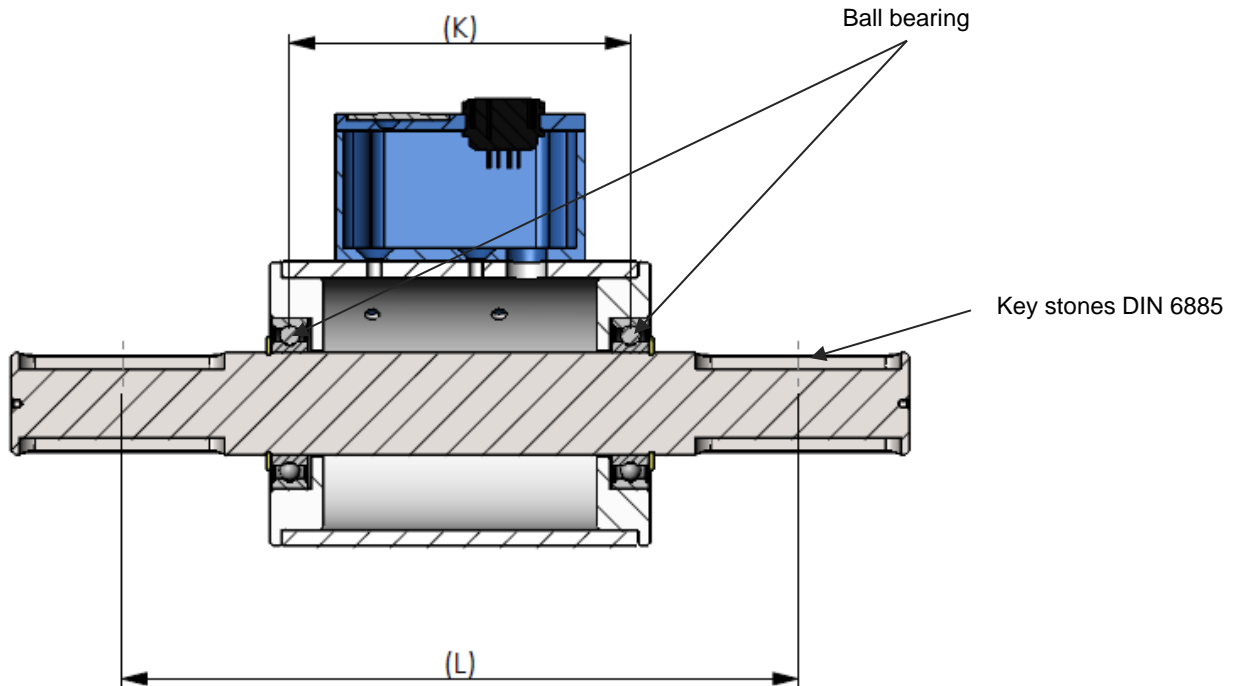

Ball bearing							
Shaft ending	Distance K [mm]	Description	Outer diameter [mm]	Inner diameter [mm]	Max. rotation of bearing [rpm]	Load rating [kN]	
						Dyn. C	Stat. C ₀
Ø 15 mm	82.0	E2.6202-2Z/C3	35	15	25000	7.8	3.75
Ø 25 mm	83.4	61905-2Z	42	25	18000	7.02	4.3
Ø 40 mm	114.6	6008-2Z	68	40	11000	17.8	11.6

Dimensions of key stone groove (mm)				Key stone DIN 6885			Key stone-position
Shaft ending	Width	Depth	Length	Height	Length	Number	Distance L
Ø 15 mm	5N9	3	25.5	5	25	1	130.5
Ø 25 mm	8N9	4	50.5	7	50	2	165.5
Ø 40 mm	12N9	5	90.5	8	90	2	252.0

It is recommended to tolerate the hub diameter with H7-clearance. In the situation of dynamic loads the shaft should be supported with a friction grip, a form lock or a coupling.

Torque Sensor

Series 3000 and Series 4000

6. Connection Plan

Pin assignment at Sensor.
Presentation: Top view

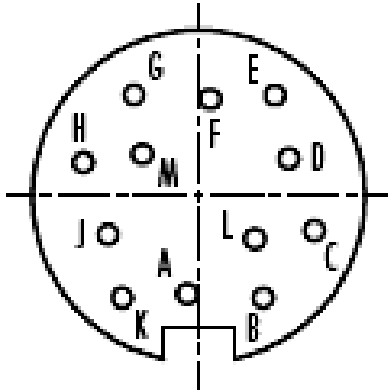

Model Binder Series 423/723/425 Item number: 09-0132-90-12 Colour code according to DIN 47100			
Pin	Colour	Description	Value
A	White	Supply voltage V_{CC}	11 V ... 28 V
B	Brown	Ground GND	
C	Green	Analog Out	0 V ... 10 V
D	Yellow	Analog GND	
E	Grey	PWM / Frequency / 4-20 mA	
F	Pink	Angle Ch A /	0 V ... 5 V
G	Blue	Angle Ch I	0 V ... 5 V
H	Red	Angle Ch B	0 V ... 5 V
I	Black	-	
K	Violet	For internal use only	Do not connect
L	Grey-Pink	For internal use only	Do not connect
M	Red-Blue	Digital GND	

Connection Plan

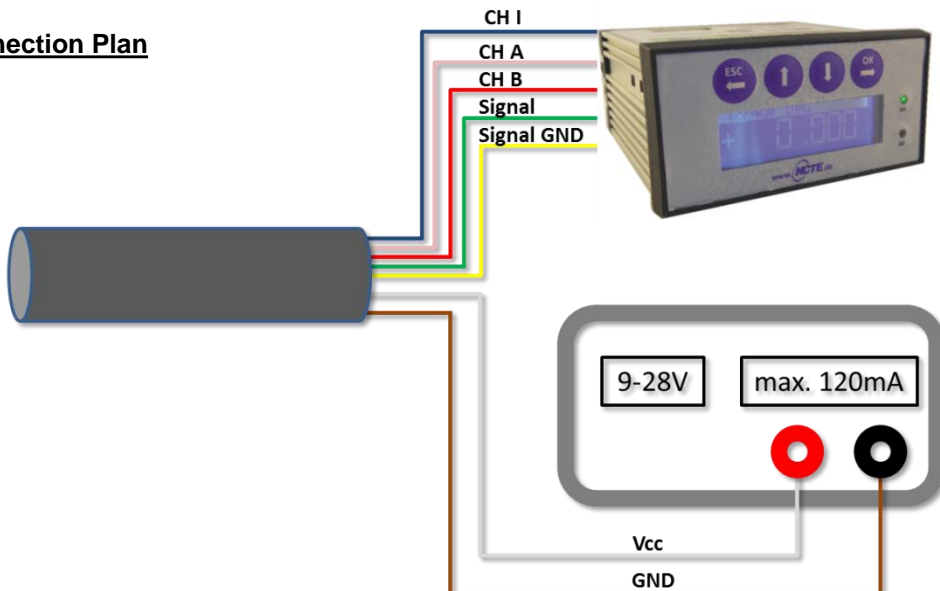

Torque Sensor

Series 3000 and Series 4000

7. Operating Instructions

Field of Application

The torque sensor is intended for the use in industrial applications. (e.g. test bench).

Scope of Delivery

The torque sensor set consists of the sensor itself (signal pick-up and signal processing integrated into sensor housing), one connecting cable with a soldered plug, key stones and the instruction manual.

Installation and Removal

Make sure to install the sensor shafts exactly with the proper aligned connecting shafts. The key stone adapter / square endings of the connecting shafts are to be attached forceless to the corresponding ones of the sensor. The sensor is not designed as a step bearing. No external axial or radial force should be on the housing of the sensor by fixing it. In case that the bending or radial forces could not avoided the ball bearing of the sensor must be double-checked. The allowed bearing forces are listed in (Chapter 6. Dimensions). The M4-screw threads on the side are only for fixing the sensor housing and keeping it from distortion. A maximum cable length of 5 m must not be exceeded. Using a cable or connector other than supplied by NCTE, or a similar cable that is of a different length may affect the overall performance of the sensor.

DO NOT REMOVE THE SHAFT WITH TORQUE APPLIED TO THE SENSOR.

Offset Adjustment

If required the zero point output signal (5 V) can be adjusted by pressing the Tare-button. By factory default the sensor is set to 5 V at Null torque.

Interface Description

Mechanical connection:

The key stone adapters on both ends of the measurement shaft are intended for torque transmission.

Electrical connector:

On the sensor housing there is a 12-pin socket for the power supply and the signal output.(see Chapter 7. Connection Plan).

Operation (in regular case or in optimal case)

Optimal measurement parameters may be achieved when the sensor is applied in accordance to the specification. Use the sensor only for short periods of time at the maximum rotational speed. By compliance with the specification the sensor works generally trouble-free and maintenance-free.

Irregular Operation, Measures against Disturbance

The presence of external electromagnetic or magnetic fields can lead to irregular measurement results. The mechanical overload on the sensor (e.g. exceeding of maximum allowed torque or severe vibrations) may cause damage to the sensor and in consequence the incorrect signal output. In such cases the sensor must be reset (see Point 8.4 Offset Adjustment). If this does not help, do not open the sensor but contact **NCTE AG** directly for assistance.

Torque Sensor

Series 3000 and Series 4000

Commissioning

After sensor installation pay attention to the followings:

- Switch on the power supply unit and check the supply voltage. Peak voltage to the sensor must be avoided! Be sure to verify the power supply voltage before connecting the sensor!
- Connect the sensor to the power supply unit by using the delivered cable.
- Connect the sensor output to a high-resistance device such as an A/D converter, oscilloscope, PC measurement board. The sensor should be in mechanical unloaded state while connecting it.

Tare function and error indication:

Series 3000/Series 4000 contains a LED button on the housing surface. Pressing the button will set the signal output to 5 V. The illumination of the button serves as a function / malfunction indicator.

Functional indicator:

- LED off: missing power supply or sensor is damaged
LED on: Sensor is ready.

Error indicator:

LED flashes: The sensor is not ready.

Flashing of LED can have several possible causes. Various causes are interpreted through a flash code. After each flash code the LED makes a short pause before repeating the code.

- 2x flashing: Magnet field sensors defective.
4x flashing: Electronics defective.

Service / Maintenance

Service-contact:

Tel.: ++49 89 66 56 19 0

Fax: ++49 89 66 56 19 29

Maintenance:

The sensor is free of maintenance, NCTE advises a yearly recalibration. The ball bearing is designed for a lifetime of 5000 h.

Disposal

For purposes of disposal please send the device back to NCTE AG.

Handling and Transport

While handling, storing and transporting keep sensor away from magnetic and electromagnetic fields which may exceed the allowed maximum range of EMC listed in Chapter 3. Technical Characteristics of the Sensor.

Precautions

- Do not open the sensor under any circumstances.
- Do not remove or loosen the locking rings on the shaft ends.
- The mounting nut of the socket as well as the fixing screws should not be loosened or tightened.
- Use only a separate power supply for the sensor
- Use the sensor only according to the specification (Chapter 3. Technical Characteristics of the Sensor).
- Keep the sensor away from magnetic and electromagnetic fields which may exceed the allowed maximum range of EMC (Chapter 3. Technical Characteristics of the Sensor)
- The sensor is not designed as a step bearing. The existing fixing possibilities serve exclusively for preventing the sensor from distortion.

8. Calibration and Accuracy Class

The exact data about the sensor is given in the enclosed factory calibration certificate. Except the sensor type this certificate also contains the exact calibration data. Each sensor has its own calibration value which is listed in the calibration certificate as well as on the label of the sensor. The calibration certificate also shows the accuracy of each sensor. The accuracy class of an NCTE torque sensor means that the largest single deviation of all values represented in percentage is either smaller than or equal to the value listed in the accuracy class.

Calibration value:

The calibration characteristic value shows how much the output signal changes per torque. There is no difference whether the torque is directed to the left or to the right.

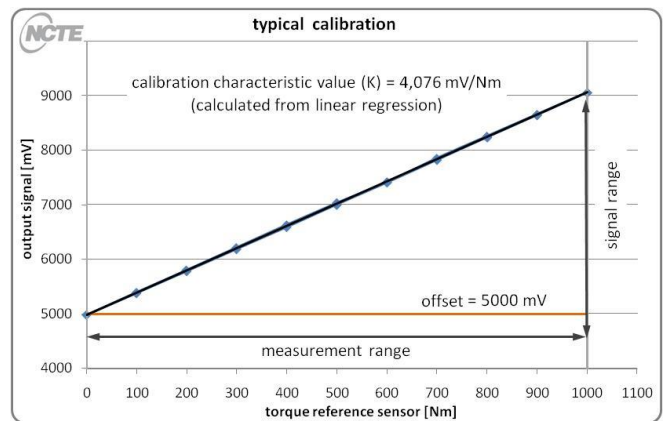

Hysteresis:

Hysteresis expresses the biggest difference between up- and downwards branches at one torque level in percentage.

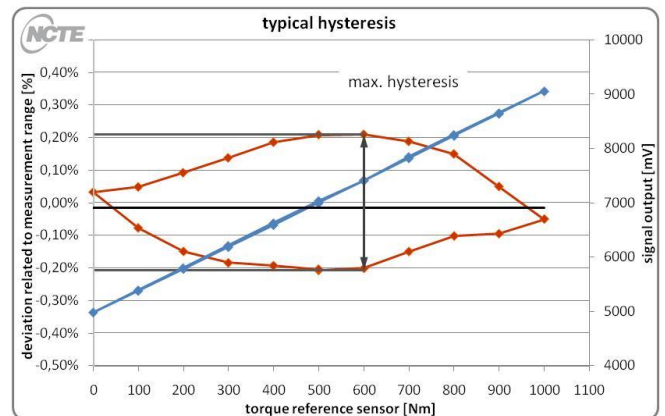

Rotational Signal Uniformity (RSU):

RSU is a signal variation created during 360° rotation of the sensor shaft without torque. The modulation is the difference between minimal and maximal values during this single rotation. RSU is generated by small homogeneities in the magnetic field and depends mostly on the property of the sensor shaft.

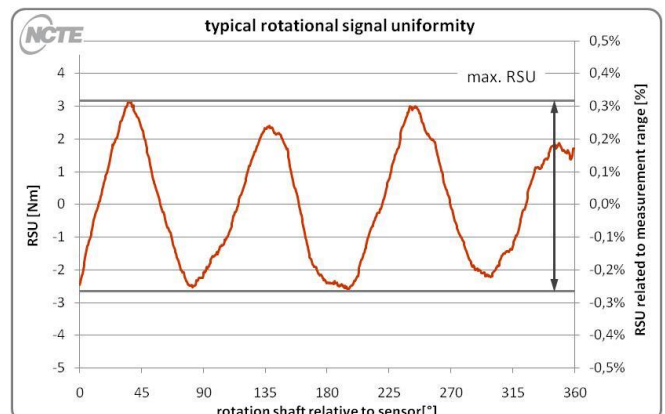

Torque Sensor

Series 3000 and Series 4000

9. Versions and Order Options Series 3000

Series 3000 Accuracy 0,2%					
		Option 1: Measurement range			
	5	0	Nm		
	1	0	0	Nm	
	2	5	0	Nm	
	5	0	0	Nm	
	1	0	0	0	Nm
	2	0	0	0	Nm
		Option 2: Angle sensor			
	0	without angle sensor			
	1	with angle sensor 360 P / Rev. (optical)			
		Option 3: Output signal⁵			
	A	analog voltage output			
	S	additional current output 4-20 mA			
	P	additional PWM output			
	F	additional Frequency output 20-100 kHz			
		Option 4: Shaft ends⁶			
	0	Standard round shaft ends with key stone			
	1	Square shaft ends			
	0	IP50			
	1	IP64 (without angle sensor)			

Exampel Modelnumber:

3000-0250-1-A-0-0

Serie 3000 – Measurement range 250 Nm – with angle sensor– analog voltage – key stone – IP50

Torque Sensor

Series 3000 and Series 4000

10. Versions and Order Options Series 4000

Series 4000 Accuracy 0,1%			
Option 1: Measurement range			
5 0	Nm		
1 0 0	Nm		
2 5 0	Nm		
1 0 0 0	Nm		
Option 2: Angle sensor			
0	without angle sensor		
1	with angle sensor 360 P / Rev. (optical)		
Option 3: Signal output			
A	analog voltage output		
S	additional current output 4-20 mA		
P	additional PWM output		
F	additional Frequency output 20-100 kHz		
Option 4: Shaft ends⁶			
0	Standard round shaft ends with key stone		
1	Square shaft ends		
Option 5: Protection class			
0	IP50		
1	IP64 (without angle sensor)		

Read Out Unit for all NCTE Sensors



Ord.-No. 400010-ATS001

- Compact readout box with display
- 1 torque sensor input, 0-5V and 0-10V
- 1 angle encoder input, A/B
- 2x digital output
- USB interface, Windows software included
- SD card slot

11. Contact

NCTE AG
 Inselkammerstr. 4
 82008 Unterhaching
 Germany
 Tel.: +49 89 665619-0
 Fax: +49 89 665619-29
 Email: sales@ncte.de