



## Properties

- PTO (Power Take-Off) shaft with integrated torque and angle measurement
- Non-contact measurement system, high robustness
- “Plug & Play” solution, no additional electronics required

## Performance

- Measurement range from 500 Nm to 2000 Nm
- Accuracy class 0,5 %
- Temperature range -40 °C ... +85 °C (105°C)
- IP65
- Turning speed up to 5000 rpm
- Output Signals 0-10 V / 4-20 mA / CAN Bus

## 1. Short description

The Series 7500 makes the torque- and angle-measurement in machines for agriculture and forestry industry easier and cheaper. The non-contact measurement principle shows very high robustness against mechanical and thermal influences and is maintenance-free. There are different adaptations available for the direct use of the sensors in various applications. It is therefore quite easy and quick to integrate them. The sensor is delivered as one complete unit with integrated electronics and cable.

The optional read-out unit provides both the torque- and angle-measurement on it's display as well as the data storage on an integrated SD-card automatically. The data can be read through an USB interface.

## 2. Model Series 7500

Model Series 7500			Nominal-Torque	Max. Overload	Rotational Speed
Shaft	Nr. of teeth on gear	Unit	bi-directional (+/-)	bi-directional (+/-)	[rpm]
Flange	-	[Nm]	2000	3000	5000

Subject to technical changes

# Series 7500

## Torque Sensor

### 3. Technical Characteristics

No.	Type	Unit	Series 7500	
	Accuracy class <sup>1</sup>		0.5	
		Unit	Value	
1	Linearity deviation incl. hysteresis	%ME*	< ±0.5	
2	Rotational Signal Uniformity	%ME*	< ±0.5	
3	Repeatability	%ME*	< ±0.05	
Output signal in general		Unit	Value	
4	Frequency range, -3dB point, Bessel characteristics	Hz	2500	
5	Analog signal	V	0 ... 10	4 ... 20
6	Signal at torque = Zero	V	≈ 5	≈ 12
7	Signal at positive nominal torque	V	> 5	>12
8	Signal at negative nominal torque	V	< 5	< 12
9	Calibration parameter (normed)	mV/Nm	4000 mV / Measurement range	8 mA / Measurement range
10	Output resistance	Ω	43	
11	Angle / Speed	ppr	optional angle sensor with 1024 ppr speed sensor with 1 ppr or 60ppr	
Temperature influence		Unit	Value	
12	Zero point drift over temperature	%/10 K	< 0.5	
13	Signal drift over temperature within operational temperature range <sup>2</sup>	%/10 K	< 0.5	
Power supply		Unit	Value	
14	Supply voltage	VDC	11 ... 28	
15	Current consumption (max.)	mA	100	
16	Start-up peak	mA	< 150	
17	Absolute max. supply voltage	VDC	30	
General information		Unit	Value	
18	Degree of protection acc. to EN 60529	IP	65 in connected state	
19	Reference temperature	°C	+15 ... +35	
20	Peak temperature temporary 12h	°C	-40.....-105°C excepted angle sensor	
21	Operational temperature range	°C	-40 ... +85 / -20 ... +85 with angle sensor	
22	Storage temperature range	°C	-40 ... +105	
23	Cable	m	Incl. 5 m cable with plug	
24	EMC / EMI	-	EN 61000, EN 55011	
General Information		Unit	Value	
25	Maximum measureable torque	Nm	Related to measurement range 500Nm about 625Nm, related to 2000Nm about 2300Nm	
26	Maximum torque, related to nominal torque	Nm	3000Nm depends on shaft ends	
27	Ultimate torque	Nm	4000Nm depends on shaft ends	
28	Maximum axial force	N	5kN	

\* %ME: : related to a full scale measurement range

1) The accuracy class implies that taken separately both the linearity deviation as well as the rotational signal uniformity are either lower than or equal to the value of the accuracy class. The accuracy class is not to be identified with the classification following DIN 51309 or EA-10/14.

2) The factor of transmission declines linearly up to a maximum of 0.5 % / 10 K with rising temperature due to the reduction of the elasticity.

# Series 7500 Torque Sensor

## 4. Dimensions

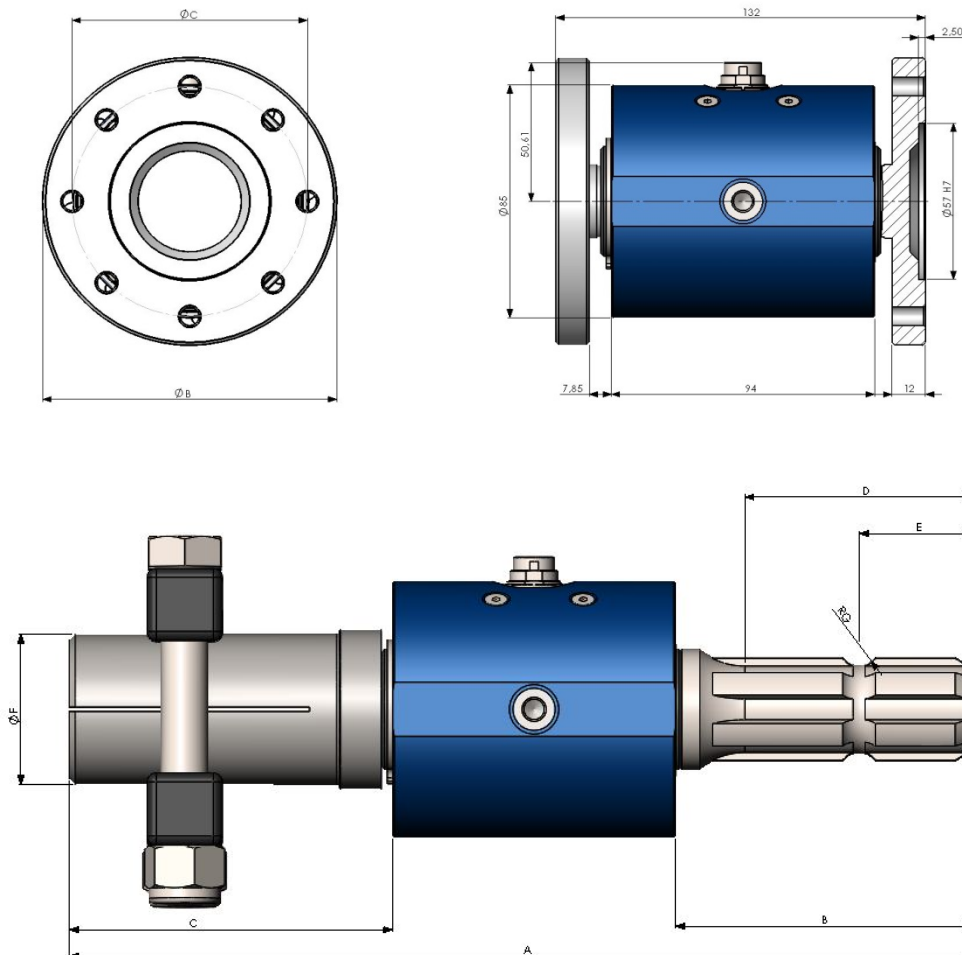

Dimensions							
Mounting parts	Dim. A [mm]	Dim. B [mm]	Dim. C [mm]	Dim. D [mm]	Dim. E [mm]	Dim. F [mm]	Dim. G [mm]
PTO 6 tooth ( 1 3/8" )	300	98	108	76	38	50	6.8
<b>Dimensions Flange</b>	<b>Strength class for bolts</b>						
Flange with bolt circle 84 mm with 8xM8	10.9	105	84	8x M8			
Customized Flange	tbd.	tbd.	tbd.	tbd.			

## 5. Angle Sensor

Optical angle sensor with 360 CPR.

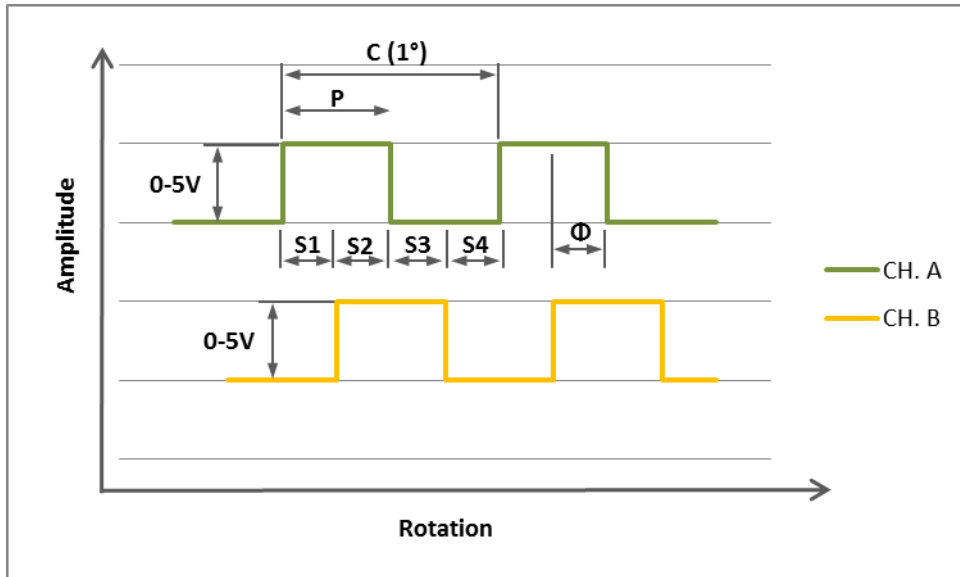

Parameter	Symbol	Min.	Typ.	Max.	Units
Pulse Width Error	$\Delta P$		15	55	$^{\circ}e$
Pulse Width Error (Ch.A, Ch. B)	$\Delta P$		15	55	$^{\circ}e$
Phase Error	$\Delta \phi$		12	60	$^{\circ}e$
LED Current	ICC		2,2	5,0	mA
High Level Output Voltage	VOH	2,4	5		V
Low Level Output Voltage	VOL			0,4	V
Rise Time	Tr		500		ns
Fall Time	tf		100		ns
Parameter	Description				
C	One cycle of 360 degrees				
P	The duration of high state of the output within one cycle. Nominally 180 $^{\circ}e$ or half a cycle.				
S	The number of electrical degrees between a transition in Channel A and the neighboring transition in Channel B. There are 4 states per cycle, each nominally 90 $^{\circ}e$ .				
$\Phi$	The number of electrical degrees between the center of high state of Channel A and the center of high state of Channel B. Nominally 90 $^{\circ}e$ .				

## 6. Speed Sensor

Magnetic (Hall Effect) speed sensor with 1 CPR or 60 CPR.

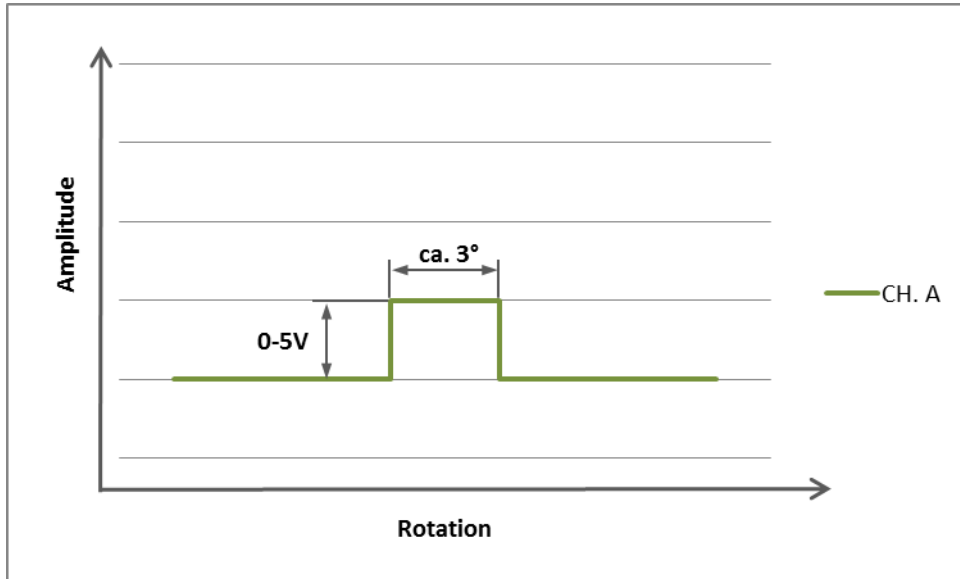

Parameter	Symbol	Min.	Typ.	Max.	Unit
Operating frequency	fop	0	-	8000	Hz
Analog band width	BW	20	40	-	kHz
High Level Output Voltage	VOH	2.4	5		V
Low Level Output Voltage	VOL		0	0.4	V

## 7. Connection Plan

Pin assignment at Sensor  
Presentation: Top view

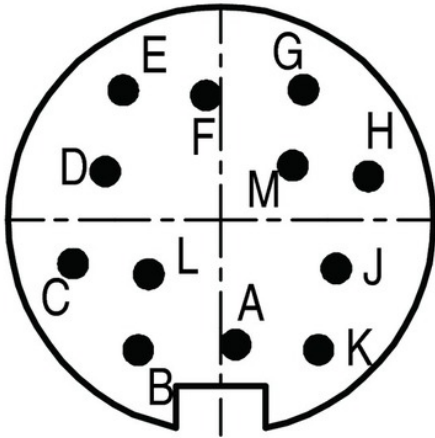

Model Binder Series M16 Connector IP67 Item number: 09-0131-90-12 Color code according to DIN 47100			
Pin	Color	Description	Value
A	White	CAN-H	
B	Brown	CAN-L	
C	Green	Angle Channel A	0 ... 5 V
D	Yellow	Angle Channel B	0 ... 5 V
E	Grey	Analog GND	
F	Pink	Analog voltage Analog current	0 ... 10 V 4 ... 20 mA
G	Blue	Ground GND	
H	Red	Supply voltage $V_{CC}$	11 ... 28 V
I	Black	-	
K	Violet	-	
L	Grey-Pink	-	
M	Red-Blue	-	

Connection plan:

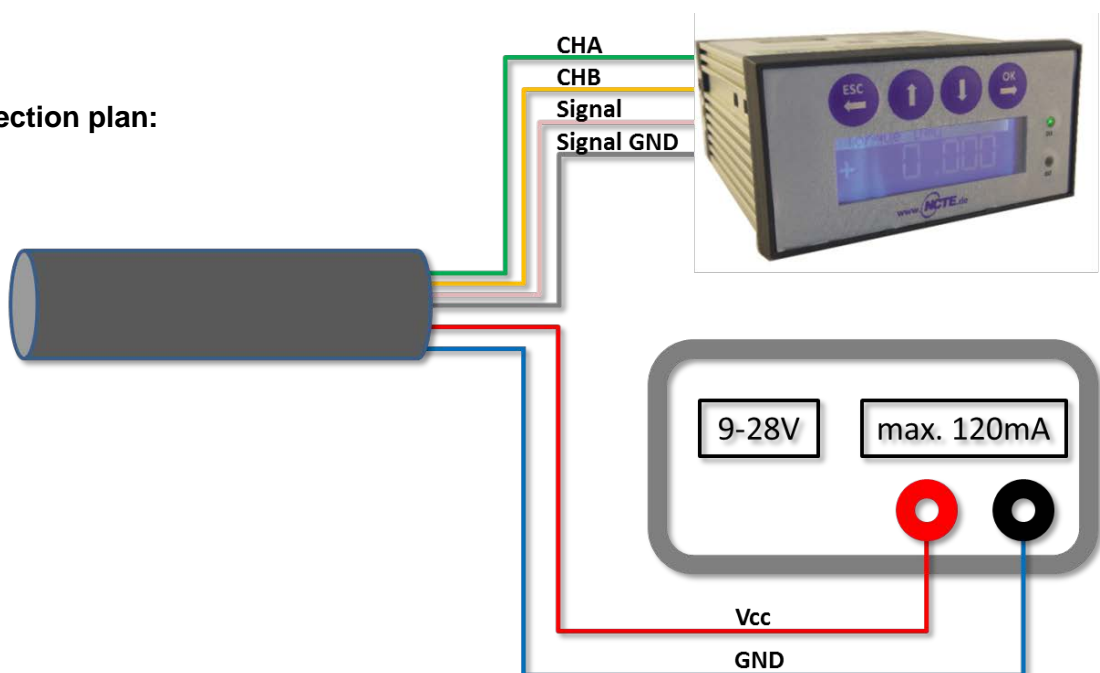

## 8. Instruction manual

### Field of Application

The torque sensor is intended for the use in agriculture, forestry industry and test benches.

### Scope of Delivery

The torque sensor set consists of the sensor itself (signal pick-up and signal processing integrated into sensor housing), one connecting cable with a soldered plug.

### Installation and Removal

Make sure to install the sensor shafts exactly with the proper aligned connecting shafts. The sensor is not designed as a pillow block. No external axial or radial force should be applied to the housing of the sensor. In case that the bending or radial forces could not be avoided the ball bearing of the sensor must be double-checked. The sensor is not designed for trailing loads, please load only compressive forces on the shaft ends. A maximum cable length of 5 m must not be exceeded. Using a cable or connector other than supplied by NCTE, or a similar cable that is of a different length may affect the overall performance of the sensor. Do not remove the shaft with torque applied to the sensor.

**The security against rotation may only occur via the M8 thread on the flattening of the housing.**

### Offset Adjustment

If required the zero point output signal (5 V / 12 mA) can be adjusted. By factory default the sensor is set to 5 V or 12 mA at zero torque.

### Interface Description

Mechanical connection:

For torque transmission use the right mounting parts from a qualified supplier, also do not hesitate to ask NCTE.

Electrical connector:

On the sensor housing there is a 12-pin socket for the power supply and the signal output. (see Chapter 6. Connection Plan).

### Operation (in regular case or in optimal case)

Optimal measurement parameters may be achieved when the sensor is applied in accordance to the specification. Use the sensor only for short periods of time at the maximum rotational speed. By compliance with the specification the sensor works generally trouble-free and maintenance-free.

### Irregular Operation, Measures against Disturbance

The presence of external electromagnetic or magnetic fields can lead to irregular measurement results. The mechanical overload on the sensor (e.g. exceeding of maximum allowed torque or severe vibrations) may cause damage to the sensor and in consequence the incorrect signal output. In such cases the sensor must be reset. If this does not help, do not open the sensor but contact NCTE directly for assistance.

## Commissioning

After sensor installation pay attention to the followings:

- Switch on the power supply unit and check the supply voltage. Peak voltage to the sensor must be avoided! Be sure to verify the power supply voltage before connecting the sensor!
- Connect the sensor to the power supply unit by using the delivered cable.
- Connect the sensor output to a high-resistance device such as an A/D converter, oscilloscope, PC measurement board. The sensor should be in mechanical unloaded state while connecting it.

## Service / Maintenance

Service-contact:

Tel.: +49 89 665619 0

Fax: +49 89 665619 29

Maintenance:

The sensor is free of maintenance, NCTE advises a yearly recalibration. The ball bearing is designed for a lifetime of 5000 h.

## Disposal

For purposes of disposal please send the device back to NCTE.

## Handling and Transport

While handling, storing and transporting keep sensor away from magnetic and electromagnetic fields which may exceed the allowed maximum range of EMC listed in Chapter 3. Technical Characteristics of the Sensor.

## Precautions

- Do not open the sensor under any circumstances.
- Do not remove or loosen the locking rings on the shaft ends.
- The mounting nut of the socket as well as the fixing screws should not be loosened or tightened.
- Use only a separate power supply for the sensor
- Use the sensor only according to the specification (Chapter 3. Technical Characteristics of the Sensor).
- Keep the sensor away from magnetic and electromagnetic fields which may exceed the allowed maximum range of EMC (Chapter 3. Technical Characteristics of the Sensor)
- The sensor is not designed as a pillow block. The existing fixing possibilities serve exclusively for preventing the sensor from rotation.



**Caution Type IP 65 in long-term usage the surface of the sensor can reach 90 degree Celsius, please be careful and use protection!**



**Caution! Before starting, please check the strength of the connection screw and tighten it if necessary with Right torque (M10 – 70Nm)**



## 9. Order options

Series 7500 Accuracy 0,5 %	
<b>Measurement range</b>	
500	Nm incl. 5 m cable
1000	Nm incl. 5 m cable
2000	Nm incl. 5 m cable
XXXX	Selectable between 500 Nm and 2000 Nm incl. 5m cable
<b>Option 1: shaft end "left"</b>	
0	Flange with bolt circle 84mm with 8xM8
1	PTO shaft 6 teeth ( 1 3/8" ) ≤ 2000 Nm
2	PTO bush 6 teeth ( 1 3/8" ) ≤ 2000 Nm
XX	Customized flange
<b>Option 2: shaft end "right"</b>	
0	Flange with bolt circle 84mm with 8xM8
1	PTO shaft 6 teeth ( 1 3/8" ) ≤ 2000 Nm
2	PTO bush 6 teeth ( 1 3/8" ) ≤ 2000 Nm
XX	Customized flange
<b>Option 3: Angle sensor</b>	
0	without angle sensor
1	Angle sensor 360 PPR nur IP50
2	Speed sensor 1 CPR
3	Speed sensor 60 CPR
<b>Option 4: Output signal</b>	
<b>A</b>	Analog voltage 0-10 V
<b>S</b>	current output 4-20 mA
<b>C</b>	CAN Bus (only Speedsensor)
<b>Option 5: IP Protection</b>	
0	IP 50
1	IP65 only Speedsensor
7500	

### Read Out Unit for all NCTE Sensors



Ord.-No. 400010-ATS001

- Compact readout box with display
- 1 torque sensor input, 0-5V and 0-10V
- 1 angle encoder input, A/B
- 2x digital output
- USB interface, Windows software included
- SD card slot

## 10. Contact

NCTE AG  
Inselkammerstr. 4  
82008 Unterhaching  
Germany  
Tel.:+ 49 89 665619-0  
Fax:+ 49 89 665619-29  
Email: [sales@ncte.de](mailto:sales@ncte.de)